

## GROUNDING FITTINGS

### 1. Grounding Clamp

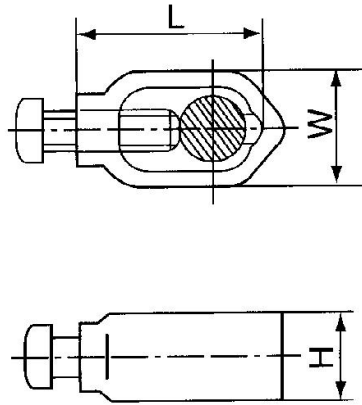

Catalog No.	Dimensions (mm)			Weight (kg)	Coating
	L	W	H		
GDX-16	50	32	25	0.85	Hot-dip galvanized
GDX-16	50	32	25	0.85	Copper plated
GDX-16	42	27	25	0.20	Brassing

The body is made of malleable iron or brassing. The bolt is hot-dip galvanized steel or brassing.

### 2. Grounding Rod

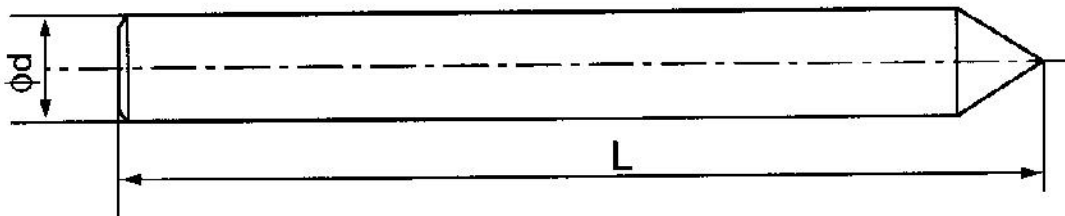

Catalog No.	Dimensions (mm)		Weight (kg)	Coating
	d	L		
JDX-1410	14	1000	1.2	Hot-dip Galvanized
JDX-1420	14	2000	2.4	
JDX-1610	16	1000	1.6	
JDX-1620	16	2000	3.2	
JDX-1630	16	3000	4.7	
JDT-1410	14	1000	1.2	Copper plated
JDT-1420	14	2000	2.4	
JDT-1610	16	1000	1.6	
JDT-1620	16	2000	3.2	
JDT-1630	16	3000	4.7	
JBT-1410	14	1000	1.25	Copper coated
JBT-1420	14	2000	2.5	
JBT-1610	16	1000	1.68	
JBT-1620	16	2000	3.36	
JBT-1630	16	3000	4.95	

The grounding rods are made in according to three coated ways. "JDX" type are made of hot-dip galvanized steel, "JDT" type are made of copper plated steel, "JBT" type are made of copper coated steel.

### 3. Insulator Pin

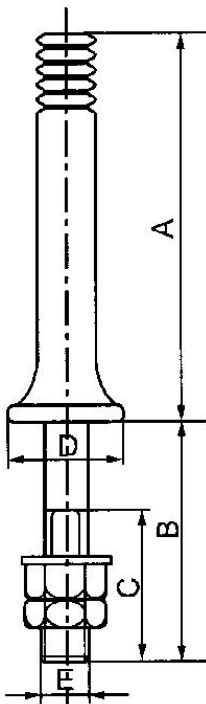

Catalog No.	Steel Head A(inch)	Dimensions (mm)					Weight (kg)	Remarks
		A	B	C	D	E		
GJB-20	Re15	115	140	75	32	18	0.8	For wood crossarms
GJB-22	Re15	165	140	75	38	18	0.99	
GJB-24	Re15	230	140	75	40	22	1.59	
GJB-26	Re16	165	140	75	44	18	1.28	
GJB-28	Re16	230	140	75	50	22	2.09	
GJB-30	Re16	305	140	75	63	22	2.84	For Steel crossarms
GJB-21	Re15	115	50	45	32	18	0.65	
GJB-23	Re15	165	50	45	38	18	0.89	
GJB-25	Re15	230	50	45	40	22	1.37	
GJB-27	Re16	165	50	45	44	18	1.10	
GJB-29	Re16	230	50	45	50	22	1.87	
GJB-31	Re16	305	50	45	63	22	2.62	

The body is made of hot-dip galvanized drop forged steel, lead pin-head meets BS standard.

#### 4. Insulator Pin

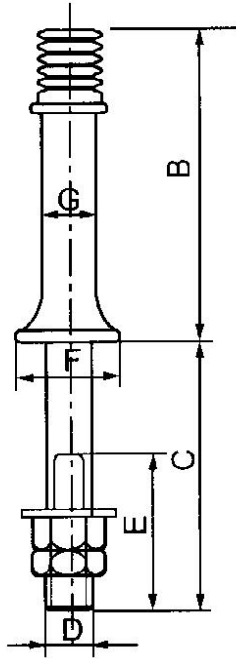

Catalog No.	Steel Head A (inch)	Dimensions (mm)						Weight (kg)	Remarks
		B	C	D	E	F	G		
GJA-3	1	127	140	16	76	50	20	1.20	For wood crossarms
GJA-5	1	152	146	16	76	50	20	1.28	
GJA-6	1	152	165	16	76	50	20	1.35	
GJA-7	1	152	165	20	82	50	22	1.50	
GJA-13	1-3/8	152	178	20	76	76	25	1.55	
GJA-14	1-3/8	203	178	20	76	76	25	1.70	
GJA-17	1-3/8	254	178	20	76	89	28	2.00	
GJA-8	1	127	44	20	38	44	16	0.95	For Steel corssarms
GJA-9	1	127	44	12	38	50	20	1.00	
GJA-16	1	152	44	16	38	50	20	1.20	
GJA-11	1	152	44	16	38	50	21	1.30	
GJA-20	1-3/8	178	44	20	38	76	25	1.35	
GJA-21	1-3/8	203	44	20	38	76	25	1.45	
GJA-24	1-3/8	254	44	20	38	80	28	1.68	
GJA-25	1-3/8	303	44	20	38	80	28	1.90	

The body is made of hot-dip galvanized drop forged steel, lead pin-head meets ANSI standard.

#### 5. Pole Top Pin

Catalog No.	Steel Head A (inch)	Dimensions (mm)					Weight (kg)
		B	F	H	D	E	
GJQ-1266	1	127	17.5	254	406	-	1.52
GJQ-1368	1	76	17.5	229	456	76	1.85
GJQ-740	1	127	21	279	508	76	2.70
GHQ-720	1-3/8	127	21	279	508	-	2.90

Made of hot-dip galvanized steel. Lead Thread Pin meets ANSI standard.

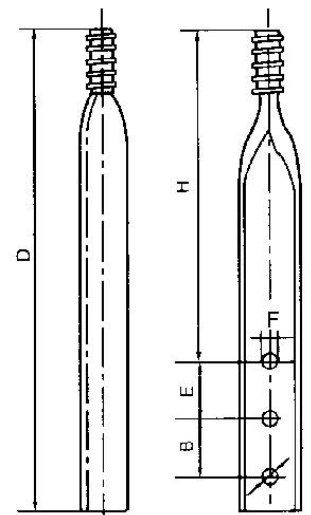

## 6. Ground Wire Support

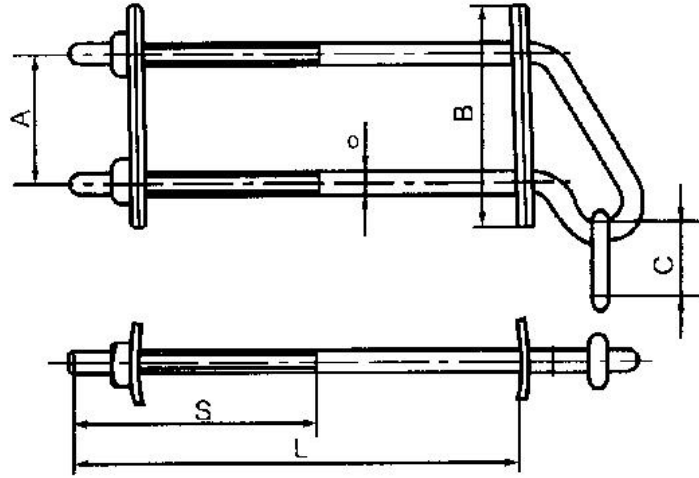

Catalog No.	Dimensions (mm)						Weight (kg)
	L	S	A	B	C	Φ	
DZ-01	292	127	102	178	57	16	2.8
DZ-02	343	191	102	178	57	16	2.9

Made of hot-dip galvanized steel.

## 7. Guy Attach

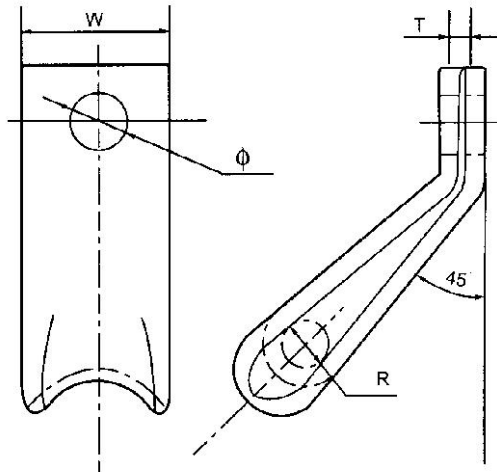

Catalog No.	Dimensions (mm)				Weight (kg)
	W	T	Φ	R(Min.)	
LX-11	40	6	17.5	6	0.50
LX-22	50	6	21.0	8	0.50

Made of hot-dip galvanized steel.

## 8. Guy Attachment

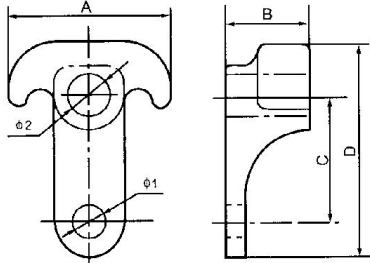

Catalog No.	Dimensions (mm)						Weight (kg)
	A	B	C	d	$\Phi_1$	$\Phi_2$	
LX-01	80	40	62	105	12.7	22	0.70
LX-02	84	34	62	105	14.3	22	0.74

Made of hot-dip galvanized malleable iron.

## 9. Stay Rod

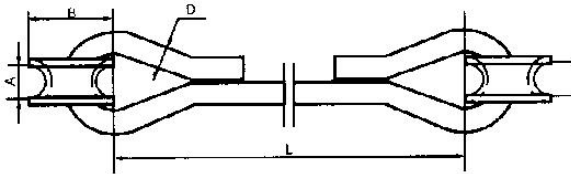

Catalog No.	Dimensions (mm)				Weight (kg)
	A	B	D	L	
LG-01	17.5	47	12	2800	3.80
LG-02	17.5	47	16	3200	6.70
LG-03	22.0	47	22	3800	13.60

Made of hot-dip galvanized steel.

## 10. Eye Bolt With Thimble

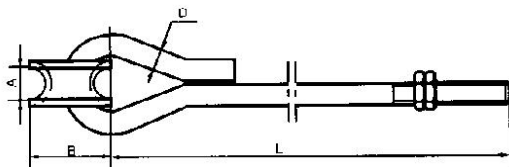

Catalog No.	Dimensions (mm)				Weight (kg)
	A	B	D	L	
LG-11	17.5	47	16	1828	3.90
LG-12	22.0	51	20	2438	6.72
LG-13	22.0	65	20	3048	11.50

Made of hot-dip galvanized steel.

### 11. Twin Eye Nut

Catalog No.	Dimensions (mm)						Weight (kg)
	A	B	C	D	E	F	
4005	32	25	17	16	32	35	0.70
4007	32	25	17	20	32	35	0.68

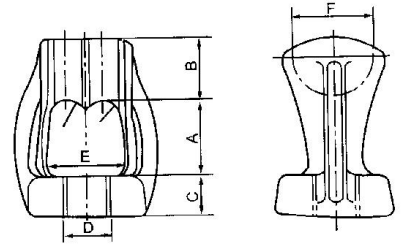

Made of hot-dip galvanized drop forged steel.

### 12. Oval Eye Nut

Catalog No.	Dimensions (mm)						Weight (kg)
	A	B	C	D	E	F	
4015	67	44	19	16	13	29	0.25
4017	76	44	19	20	13	38	0.28

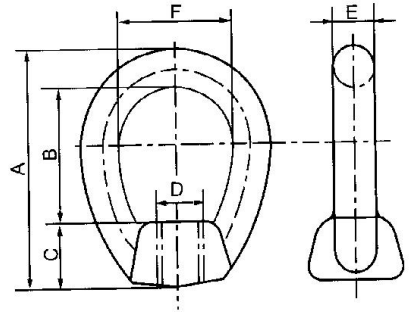

### 13. Angle Thimbleye

Made of hot-dip galvanized drop forged steel.

U.T.S is 62kN.

Weight is 0.6kg.

